

Culligan

Twist Sparkling

Customizable Flavored Enhanced
Sparkling Water Dispenser

Elevate hydration with the Twist Sparkling! This sleek, new Enhanced Water System offers cold, ambient, hot, or chilled sparkling water with optional flavor selections, making it a healthier, sustainable, and cost-effective alternative to traditional sodas.





Specifications

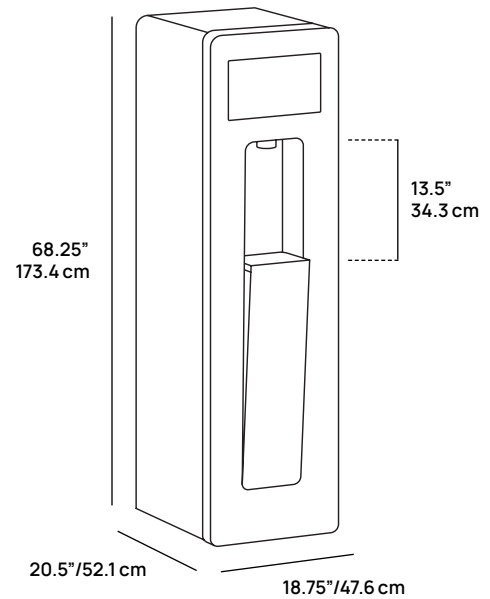

Product Details

Perfect for any breakroom, customer waiting area, or workplace cafeteria, the Twist Sparkling provides a refreshing pick-me-up, boosting energy and productivity. The beautiful and intuitive touchscreen allows users to effortlessly customize flavor intensity, create flavor combinations, adjust sweetener strength, and select their preferred sparkling level while counting 12 oz. bottles saved. With advanced multi-stage filtration and UVC LED protection at the point of dispense, you can always count on the highest quality water. Plus, remote system monitoring ensures proactive service support. Enjoy crisp, customizable sparkling water effortlessly with the Twist Sparkling.

 Commercial Capacity

Enjoy Flavored and Enhanced Sparkling Water with the Twist Sparkling

- Cold, ambient, and hot filtered water
- Chilled sparkling filtered water
- 7 zero-calorie, fruit-inspired flavors available and 1 Stevia sweetener to boost and brighten flavor profile
- State-of-the-art 15.6" dynamic color touchscreen for effortless customization of the 4 installed flavor and sweetener enhancements
- Large 13.5" dispensing area perfect for most reusable bottles
- Advanced multi-stage filtration to produce clean, great-tasting drinking water on-demand
- Point-of-dispense UVC LED dispensing protection technology
- Typically fits 20 lb. CO₂ cylinder inside the machine
- User-friendly design with remote system monitoring for easy replenishment of flavors and enhancements and proactive service support and protection
- Drink capture feature to track users most used flavors and sweetener usage

Dimensions	68.25" h x 18.75" w x 20.5" d 173.4 cm h x 47.6 cm w x 52.1 cm d Cord/water connection add 3" (7.6 cm) to depth
Dispensing Area Height	13.5" / 34.3 cm
Screen Size	15.6" / 39.6 cm
Weight	230 lbs / 104.3 kg
Cold Tank Capacity	20 gal/hr / 75.7 liters/hr
Hot Tank Capacity	0.4 gal / 1.5 liters
Water Pressure	50-80 PSI
Rated Voltage/Frequency	115V/60Hz
Power Consumption	7.5A
Model Number	830

Flavors

- Watermelon
- Pineapple Strawberry
- Cucumber
- Peach Mango
- Cherry Lime
- Mixed Berry
- Natural Sweetener Made with Stevia Extract
- *More flavors and enhancements coming soon*
- Lemon
- Pomegranate Blueberry
- Immunity Enhancement
- Electrolytes Enhancement
- Caffeine Enhancement

Culligan products are certified by independent authorized 3rd party laboratories in accordance with appropriate industry standards. To find out more about which certifications your product may have, please contact us.